



Features

- Power Amplifier with High Power Added Efficient (PAE),
 P_{out} Typically 29 dBm
- Controlled Output Power
- Low-noise Preamplifier (NF Typically 1.7 dB)
- Few External Components
- PSSO16 Plastic Package with Down Set Paddle

Description

The T0980 is a monolithic IC manufactured with Atmel's advanced SiGe technology. The IC performs a transmit and receive front-end dedicated for a frequency range of 400 MHz to 500 MHz. It consists of a Low-Noise Amplifier (LNA) and a Power Amplifier (PA) with good Power Efficiency (PAE).

Electrostatic sensitive device.
Observe precautions for handling.



SiGe Transmit/ Receive Front- end IC

T0980

Figure 1. Block Diagram

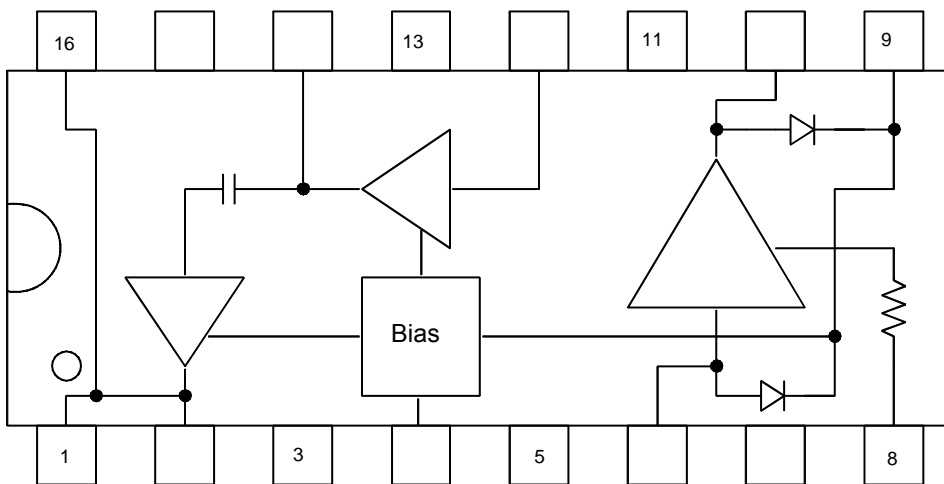

Pin Configuration

Figure 2. Pinning PSSOP16

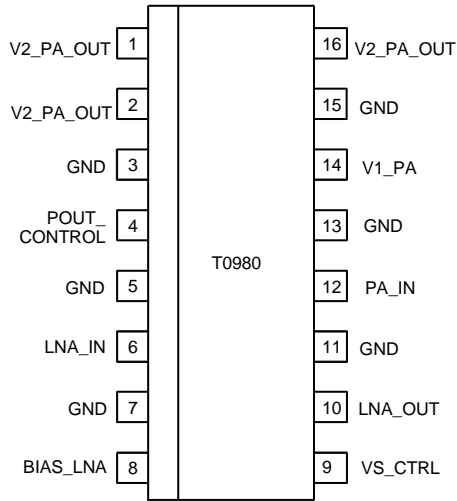

Pin Description

Pin	Symbol	Function
1	V2_PA_OUT	Inductor to power supply and matching network for power amplifier output
2	V2_PA_OUT	Inductor to power supply and matching network for power amplifier output
3	GND	Ground
4	POUT_CONTROL	Power amplifier control input
5	GND	Ground
6	LNA_IN	Low-noise amplifier input
7	GND	Ground
8	BIAS_LNA	Resistor to V_S sets the LNA current
9	VS_CTRL	Supply voltage for control of power amplifier
10	LNA_OUT	Low-noise amplifier output and supply voltage
11	GND	Ground
12	PA_IN	Power amplifier input
13	GND	Ground
14	V1_PA	Supply voltage for power amplifier
15	GND	Ground
16	V2_PA_OUT	Matching network for power amplifier output

Absolute Maximum Ratings

All voltages are referred to GND

Parameters	Symbol	Min.	Max.	Unit
Supply voltage PA, TX Pins 1, 2, 9 and 14	V_{S_PA}		4.8	V
Supply voltage LNA, RX Pin 10	V_{S_LNA}		2.8	V
Junction temperature	T_{jmax}		150	°C
Storage temperature	T_{Stg}	-55	+125	°C
Electrostatic handling HMB; Pins 1, 2, 6, 10, 12 and 16	V_{ESD}		200	V
Electrostatic handling HMB; Pins 3, 4, 5, 7, 8, 9, 11, 13, 14 and 15	V_{ESD}		2000	V

Operating Range

All voltages are referred to GND. The following table represents the sum of all supply currents.

Parameters	Test Conditions/Pins	Symbol	Min.	Typ.	Max.	Unit
Supply voltage PA	TX, Pins 1, 2, 9 and 14	V_{S_PA}		3.6	4.5	V
Supply voltage LNA	RX, Pin 10	V_{S_LNA}		2.5	2.6	V
Supply current PA	TX, Pins 1, 2, 9 and 14	I_{S_PA}		400		mA
Supply current LNA	Pins 10 and 8	I_{S_LNA}		2.5		mA
Ambient temperature		T_{amb}	-25	25	60	°C

Thermal Resistance

Parameters	Symbol	Value	Unit
Junction ambient	R_{thJA}	25	K/W

Electrical Characteristics

Test conditions (unless otherwise specified) : $V_{S_PA} = 3.6\text{ V}$, $T_{amb} = 25^\circ\text{C}$.

Parameters	Test Conditions/Pins	Symbol	Min.	Typ.	Max.	Unit
Power Amplifier ⁽¹⁾						
Supply voltage	TX, Pins 1, 2, 9 and 14	V_{S_PA}		3.6		V
Supply current	TX, Pins 1, 2, 9 and 14	I_{S_PA}		400		mA
Frequency range	TX	f	400		500	MHz
Power gain	TX	Gp		33		dB
Control voltage	TX, output power (maximum), Pin 4			2.5		V
	TX, output power (minimum), Pin 4			0.7		V
Control current	Pin 4		0		400	μA
Shut down mode	Control voltage $\leq 0.1\text{ V}$, Pins 1, 2, 9 and 14	I_{S_PA}		10		μA
Power added efficiency	TX at 450 MHz	PAE	50			%
Saturated output power	TX, input power 3 dBm	Psat		29		dBm
Harmonics	TX, input power 3 dBm	2 fo		-20		dBc
	TX, input power 3 dBm	3 fo		-20		dBc
Low-noise Amplifier						
Supply voltage	RX, Pins 8 and 10	V_{S_LNA}		2.5		V
Supply current	RX at R1 = 5.6 k Ω , Pins 8 and 10	I_{S_LNA}		2.5		mA
Frequency range	RX	f	400		500	MHz
Power gain	RX at R1 = 5.6 k Ω , Is = 2.5 mA	Gp		19		dB
Noise figure	RX at R1 = 5.6 k Ω , Is = 2.5 mA	NF		1.7	2.5	dB
Isolation	RX at R1 = 5.6 k Ω , Is = 2.5 mA	ISO		20		dB
3rd-order input interception point	RX at R1 = 5.6 k Ω , Is = 2.5 mA	IIP3		-10		dBm

Note: 1. Power amplifier should be unconditional stable, maximum duty cycle 100%, true cw-operation, maximum load mismatch 10:1 for 5 s at 3.6 V

Typical Characteristics

Figure 3. Power Sweep

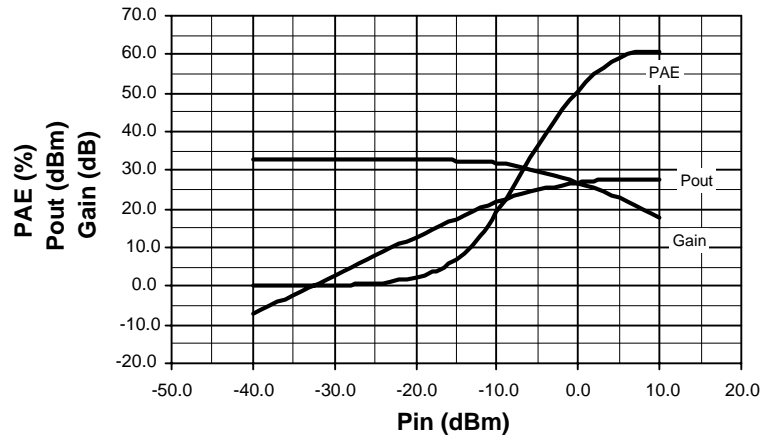

Figure 4. Ramp Sweep

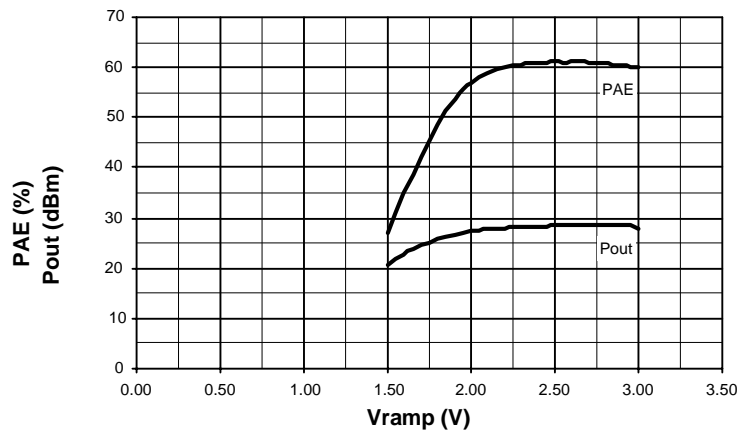

Figure 5. V_{CC} Sweep

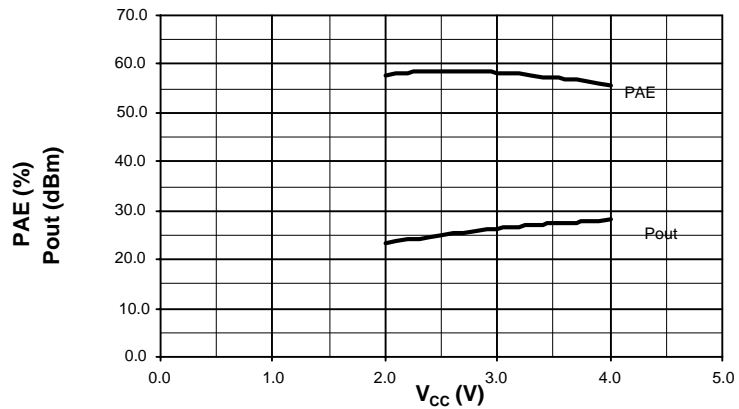
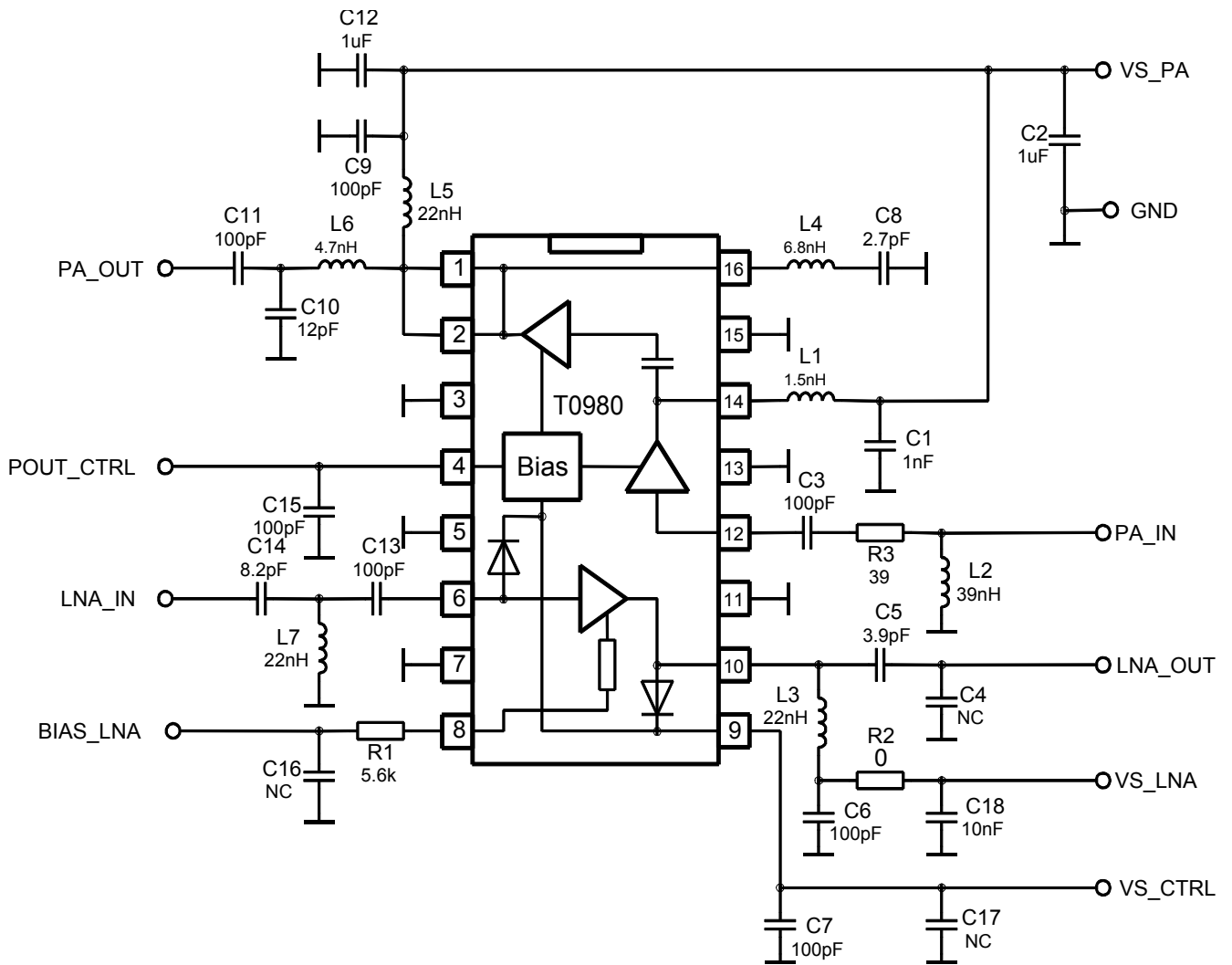

Figure 6. Typical Application Circuit (460 MHz)



Ordering Information

Extended Type Number	Package	Remarks
T0980-TJS	PSSO16	Tube
T0980-TJQ	PSSO16	Taped and reeled

Package Information

Package: PSSO16

Dimensions in mm

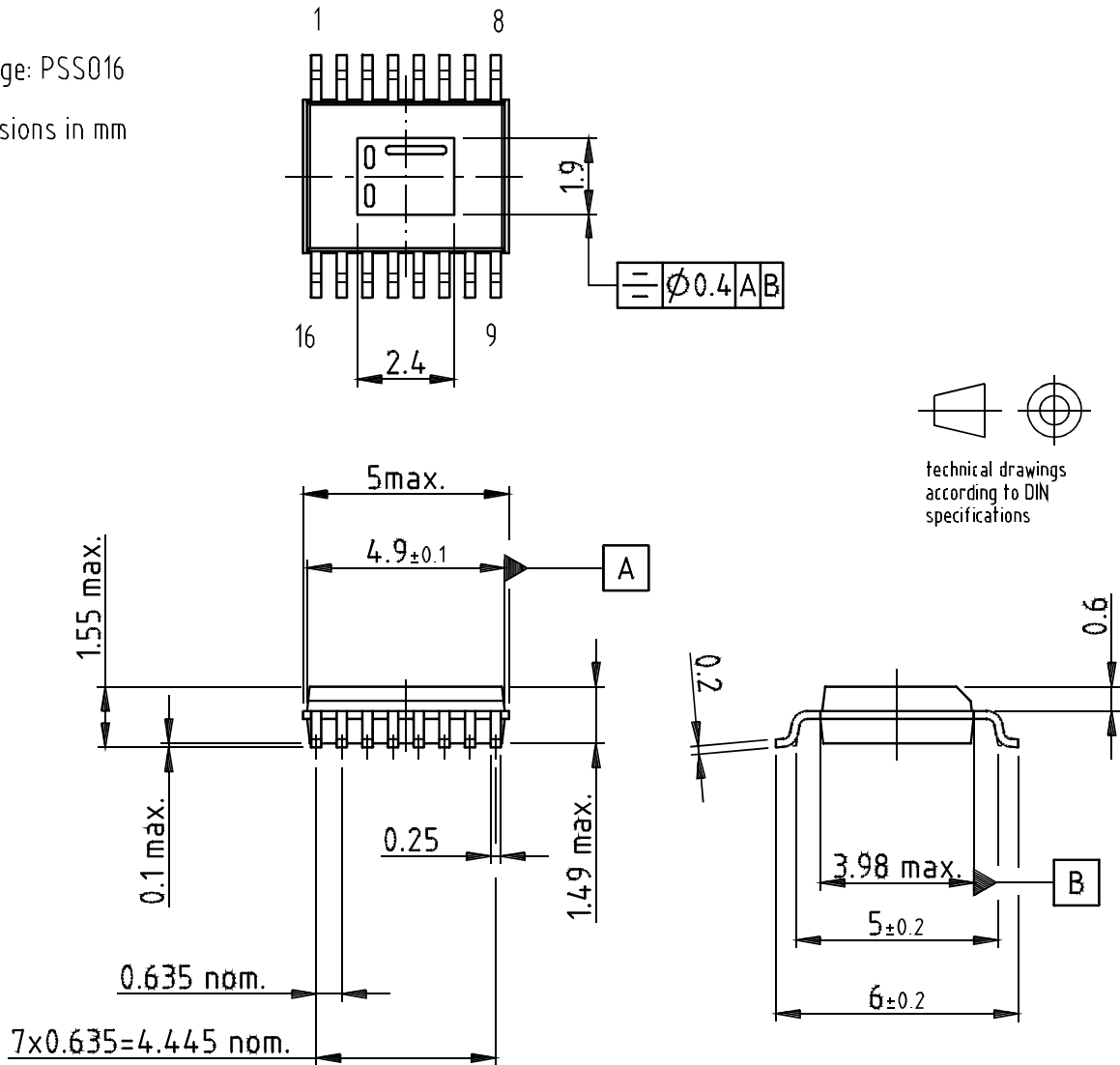

Drawing-No.: 6.543-5070.02-4

Issue: 1; 30.11.00



Atmel Headquarters

Corporate Headquarters
2325 Orchard Parkway
San Jose, CA 95131
TEL 1(408) 441-0311
FAX 1(408) 487-2600

Europe

Atmel Sarl
Route des Arsenaux 41
Case Postale 80
CH-1705 Fribourg
Switzerland
TEL (41) 26-426-5555
FAX (41) 26-426-5500

Asia

Room 1219
Chinachem Golden Plaza
77 Mody Road Tsimhatsui
East Kowloon
Hong Kong
TEL (852) 2721-9778
FAX (852) 2722-1369

Japan

9F, Tonetsu Shinkawa Bldg.
1-24-8 Shinkawa
Chuo-ku, Tokyo 104-0033
Japan
TEL (81) 3-3523-3551
FAX (81) 3-3523-7581

Atmel Operations

Memory

2325 Orchard Parkway
San Jose, CA 95131
TEL 1(408) 441-0311
FAX 1(408) 436-4314

Microcontrollers

2325 Orchard Parkway
San Jose, CA 95131
TEL 1(408) 441-0311
FAX 1(408) 436-4314

La Chantrerie
BP 70602
44306 Nantes Cedex 3, France
TEL (33) 2-40-18-18-18
FAX (33) 2-40-18-19-60

ASIC/ASSP/Smart Cards

Zone Industrielle
13106 Rousset Cedex, France
TEL (33) 4-42-53-60-00
FAX (33) 4-42-53-60-01

1150 East Cheyenne Mtn. Blvd.
Colorado Springs, CO 80906
TEL 1(719) 576-3300
FAX 1(719) 540-1759

Scottish Enterprise Technology Park
Maxwell Building
East Kilbride G75 0QR, Scotland
TEL (44) 1355-803-000
FAX (44) 1355-242-743

RF/Automotive

Theresienstrasse 2
Postfach 3535
74025 Heilbronn, Germany
TEL (49) 71-31-67-0
FAX (49) 71-31-67-2340

1150 East Cheyenne Mtn. Blvd.
Colorado Springs, CO 80906
TEL 1(719) 576-3300
FAX 1(719) 540-1759

Biometrics/Imaging/Hi-Rel MPU/ High Speed Converters/RF Datacom

Avenue de Rochepleine
BP 123
38521 Saint-Egreve Cedex, France
TEL (33) 4-76-58-30-00
FAX (33) 4-76-58-34-80

e-mail

literature@atmel.com

Web Site

<http://www.atmel.com>

© Atmel Corporation 2003.

Atmel Corporation makes no warranty for the use of its products, other than those expressly contained in the Company's standard warranty which is detailed in Atmel's Terms and Conditions located on the Company's web site. The Company assumes no responsibility for any errors which may appear in this document, reserves the right to change devices or specifications detailed herein at any time without notice, and does not make any commitment to update the information contained herein. No licenses to patents or other intellectual property of Atmel are granted by the Company in connection with the sale of Atmel products, expressly or by implication. Atmel's products are not authorized for use as critical components in life support devices or systems.

Atmel® is the registered trademark of Atmel.

Other terms and product names may be the trademarks of others.



Printed on recycled paper.